



Safety, Operation & Maintenance Manual

Douglas Titan™ IFC Floating Impact Bed



Warning: This manual must be read, understood, and followed by anyone that installs, operates, and maintains this product. Failure to follow instructions may result in serious or fatal injury.

Douglas Manufacturing Co., Inc.
300 Industrial Park Drive, Pell City, Alabama 35125
Tel: (205) 884-1200 • Fax: (205) 884-1206
Email: sales@douglasmanufacturing.com

SAFETY INFORMATION

1. Follow all federal, state, and local and owner recommended safety guidelines.
2. Before beginning work on any motorized equipment including conveyors always lockout and tag-out the equipment. Follow all OSHA, MSHA and in-house guidelines that pertain to lockout and tag-out procedures.
3. Do not allow anyone to attempt installation or operation of this unit until they have read this manual thoroughly and understand it completely.
4. Only safety trained persons and those familiar with the mechanics and mechanical nature of conveyors, and rigging for unloading, should work on or around this unit.
5. Use only safety trained, certified and licensed electricians for all electrical requirements.
6. When loading or unloading this unit make sure that you are away from power lines and use caution to prevent metal equipment from contacting power lines.
7. Do not wear loose clothes, jewelry or neckties when working on or around this unit. Long hair should be secured under a cap or bandana to prevent injury. The moving parts of this unit may catch loose clothes, jewelry, neckties or long hair and may result in serious injury.
8. Never operate this unit without guards in place. It is the customer's responsibility to install proper guards that adhere to local, state and federal, and in-house requirements to promote safety in the operation of this unit.
9. Periodically check this Impact Bed to verify that safety guards and decals are in place and working properly. It is the owner's responsibility to replace missing, worn parts and/or faded decals as required.
10. Always replace worn components with factory recommended components.
11. Safety is the responsibility of all concerned. Be aware and alert at all times. Report unsafe conditions to the owner as soon as possible and always take improperly maintained or malfunctioning equipment out of service until such time as it may be properly serviced and returned to normal, safe operating conditions.
12. Please feel free to contact Douglas Manufacturing if you have any questions concerning your Impact Bed.

Very Important: Before burning or welding, remove all flammable materials located around and below your work area so that they cannot be ignited by hot sparks or slag. Post a fire watch if you cannot see all areas affected by sparks or slag. Keep a fire extinguisher and a first-aid kit on hand at all times.

Items Needed Carpenter's Square

For Installation: Tape Measure

Torch or Drill with 13/16" diameter bits

3/4" Bolts, Nuts, and Washers for bolting support frames to structure & required wrenches

Impact Bed Rules:

1. Always have a steel trough idler of the same trough angle as the impact bed placed immediately before the impact bed.
2. Impact Beds are designed to be 1/2" to 3/4" below the bottom surface of the conveyor belt at the center roll of the trough idler.
3. Always have a steel trough idler of the same trough angle as the impact bed placed immediately after the impact bed.

Floating Impact Bed Installation:

The assembly is shipped ready to weld or bolt down to the conveyor frame. Support framing similar to that shown below is required for installation. Consult with an engineer to ensure your framing design is strong enough to handle applicable impact loads. There must be a trough idler directly before and after where the impact bed is to be installed (see page 5).

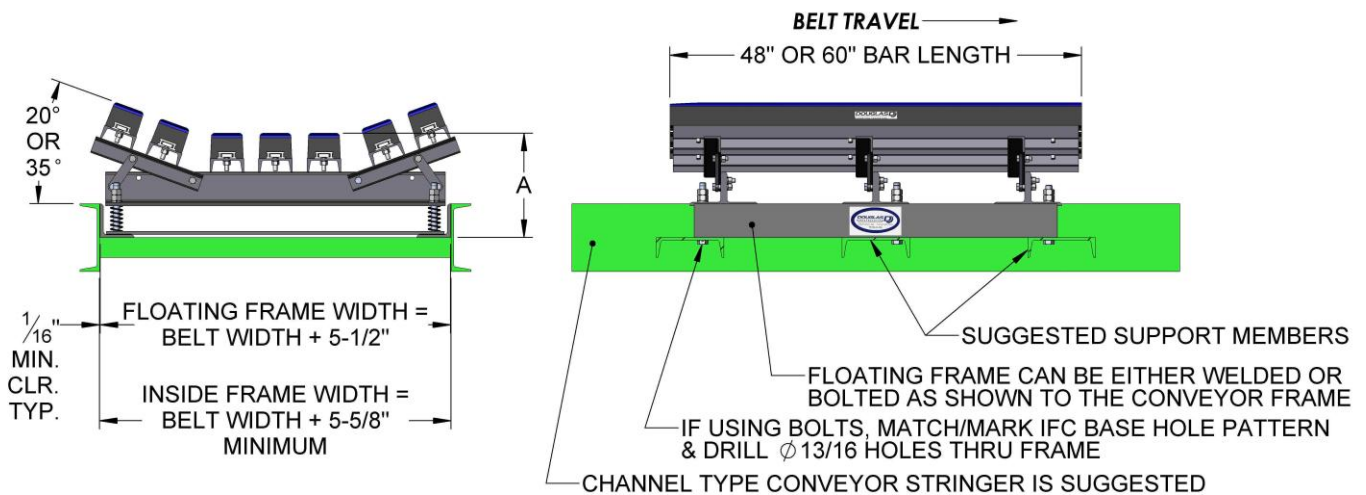

1. Inspect shipping pallet/container for damage. Report damage to delivery service immediately and fill out delivery services' claim report form. Keep any damaged goods as they may be subject to examination. If anything is missing please contact Douglas Mfg. Co. or a representative.
2. Remove the Douglas Floating Impact Bed from its shipping pallet or container. The impact bed is heavy and will require lifting equipment to move the bed and set in place.
3. Turn off and lock out/tag energy source of the conveyor system in accordance to ANSI standard z244.1-1982.
4. Remove the idlers that are currently in the load section (if any).
5. Make sure conveyor belt is centered on the conveyor.

6. Observe the direction of belt travel.
7. Mount the Floating Impact Bed with the tapered edges of the impact bars facing the tail pulley of the conveyor. This is the leading edge.
8. This Impact Bed will fold flat on either or both wing arm sides to aid installation. To do this, simply remove the Link Arm bolts.
9. Check that there is ½” to ¾” gap between the impact bars and the bottom surface of the conveyor belt. (Reference dimension “A” in the image on page 2) Shim either the Douglas Adjustable Impact Bed or adjacent trough idlers to maintain this gap.
10. A suitable support design is required, similar to that shown on page 2, prior to installation. Bolt or weld the base to the conveyor frame. Use the 13/16” holes in the floating bed base weldment as a template for marking & drilling.
11. If long enough, the bolts that shipped with this unit may be reused. Securely tighten all mounting nuts (DO NOT COMPRESS SPRINGS!).

Impact Bar Materials: see the table below for materials and specifications.

Characteristics	Bar With UHMW Cap
MSHA - Accepted for underground use	N/A
Coefficient of friction	0.5
Service Temperature	-20 to 140°F (-29 to 60° C)
Bearing layer	UHMW Polyethylene
Absorption layer	50 Shore A Durometer SBR Rubber
T-Slot	Extruded Aluminum
Fasteners	Ø12mm T-Bolts & Locknuts

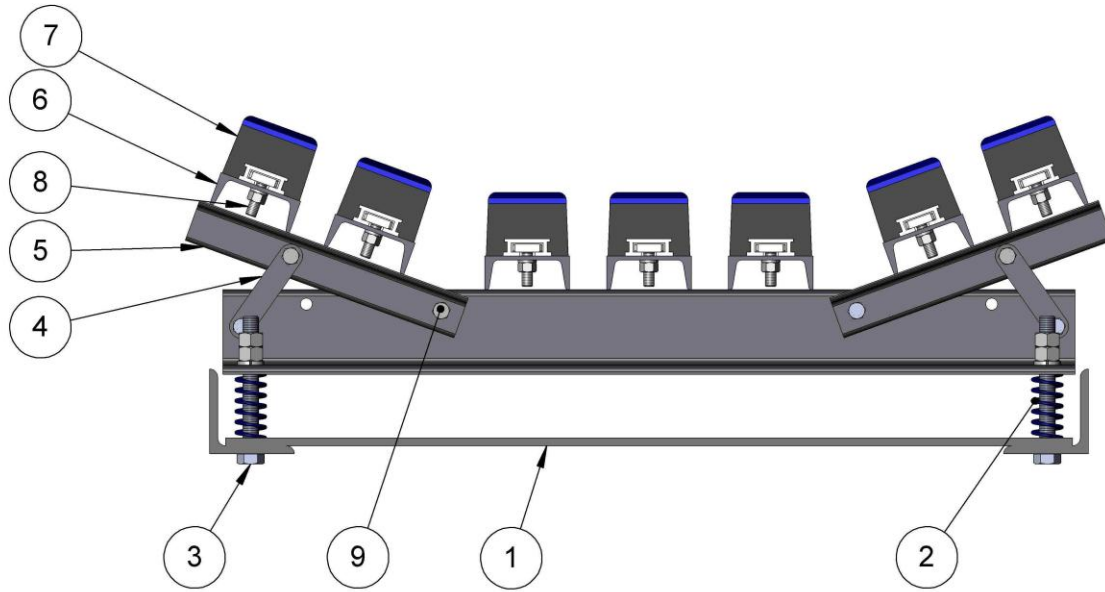

ITEM NO.	DESCRIPTION
1	FLOATING BASE WELDMENT
2	HD DIE SPRING
3	3/4" x 6-1/2" LG. HEX BOLT W/NUTS & WASHERS
4	LINK ARM FOR 20° OR 35° TROUGH ANGLE
5	WING SUPPORT ARM
6	C4 STRUCTURAL BAR HOLDER
7	IBB IMPACT BAR WITH ALUMINUM T-SLOT
8	∅ 12mm T-BOLT & LK NUT TO FASTEN BARS
9	∅ 1/2" HEX HEAD FASTENERS

Your IBA Impact Bed should have all of the factory installed components listed above.

After installation is complete:

- A. Remove all tools from the installation area.
- B. Turn on conveyor belt.
- C. After 1 hour of operation, turn off and lock out/tag out energy source according to ANSI standard.
- D. Make sure all fasteners are tight. Tighten if necessary.
- E. Inspect impact bars for wear. (A small amount of "break-in" wear may be found. This will stop once the bars wear to the conveyor belt contour.)

Following are best practice guidelines for idler placement and skirt board sealing:

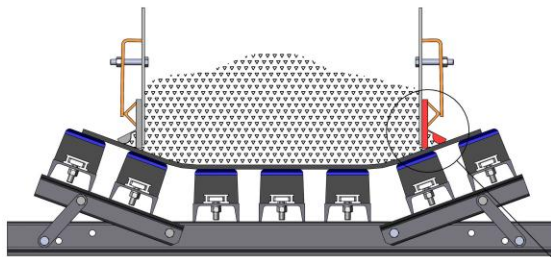
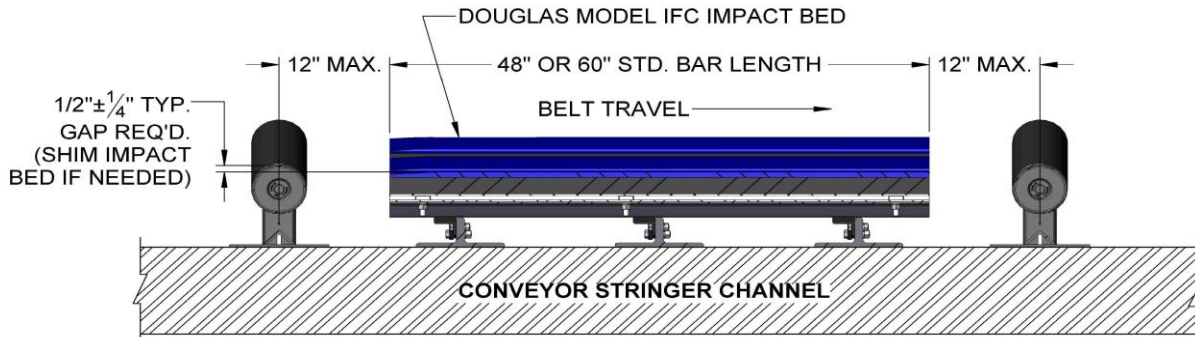

Per CEMA recommendations the inside distance between skirt plates is two thirds of the belt width maximum. Douglas recommends a skirt seal designed to provide secondary spillage protection, as shown at right.

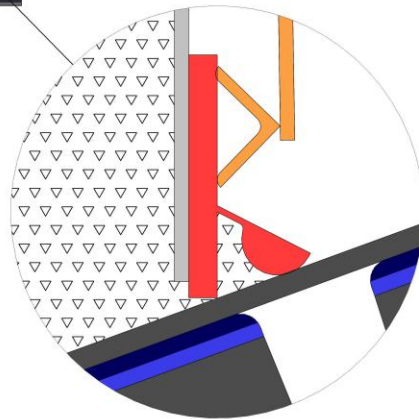

BEST PRACTICE FOR EFFECTIVE SEALING

Replacing the Impact Bars:

1. Prior to replacing worn impact bars be sure to follow lock out, tag out, and all other safety procedures.
2. To replace a worn impact bar simple loosen the T-bolt locknut (do not remove the locknut).
3. Slide the worn impact bar off of the C4 support and T-bolts.
4. Slide a new impact bar over the T-bolts and secure by tightening the locknuts on the underside of the C4 support.

Maintenance:

Every 3 to 6 months of operation the IFC Impact Bed should be inspected. Turn off and lock out/tag out energy source according to ANSI standards.

Make sure all fasteners are in place and tight. Re-tighten if necessary.

If the blue colored top cover of the bars is worn through to the black rubber, replace these bars following the guidelines above this section.

Inspect the blue die springs. Any springs that are cracked or broken must be replaced as soon as possible.

The Impact Bed Assembly will come apart in sections. Hex Head fasteners mounted in the base bars can be removed to facilitate maintenance.

Remove fines trapped between the Impact Bars with a broom or high pressure air or water.

Inspect the steel framing members for cracks or fatigue. Weld or strengthen structure as necessary.