

PREMIUM

# CONVEYOR COMPONENTS

Trusted by the Toughest Industries Around the World



**IDLERS | PULLEYS | LAGGING |**  
**IMPACT BEDS | MAGNETIC SEPARATORS | TAKE-UPS**

**DOUGLAS®**

**R** RULMECA® GROUP

# CEMA B, C, D, AND E IDLERS

## Unstoppable Performance. Unmatched Durability.

The PSV Idler is engineered for demanding CEMA B, C, D or E applications. Douglas/Rulmeca idlers are available in a wide variety of configurations including: troughing, return, impact, rubber disc return, self-aligning trough, self aligning return, scale quality and live shaft.



Equal Troughing



Unequal Troughing



Feeder / Picking



V-Return



Channel Mount Low Profile



Impact Troughing



Offset Center Roll Troughing



Return

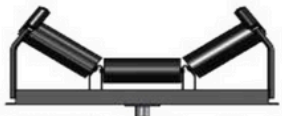

Self-Aligning Troughing



Self-Aligning Return



2-Roll Troughing



Channel Inset Return



Scale Quality Troughing



Squirrel Cage Rolls



Live Shaft Rubber Disc



Channel Inset Rubber Disc Return



Live Shaft Steel



Rubber Disc Return

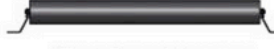

Flat Carrying Idler



Negotiator Self-Aligning Return



Rubber Disc Flat Idler



Beater Rolls

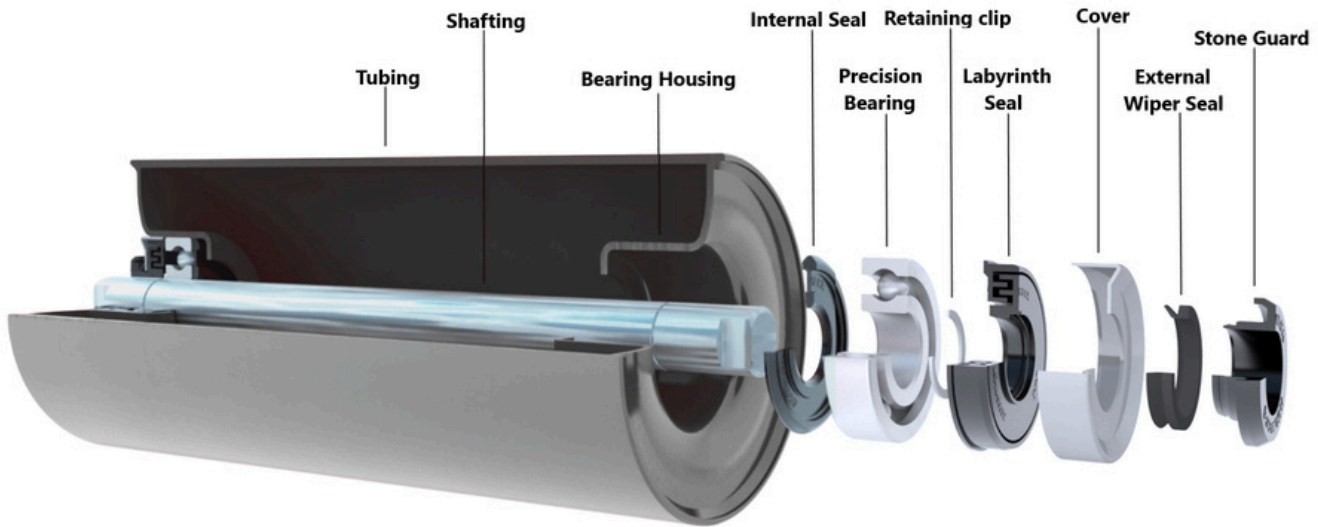

## IDLER FEATURES

- **Stone Guard** - Prevents stones and other debris from getting lodged in the roll.
- **External Wiper Seal** - A contact seal that prevents dust and water from entering the bearing.
- **Labyrinth Seal** - Grease-filled to prevent contamination from getting to the bearing.
- **Retaining Ring** - Holds bearing in place to prevent idler from shifting during side load.
- **Bearings** - Precision grooved ball bearings.
- **Counter Bore Tubing** - Protects weldment.
- **Internal Seal** - Provides protection from internal containments.

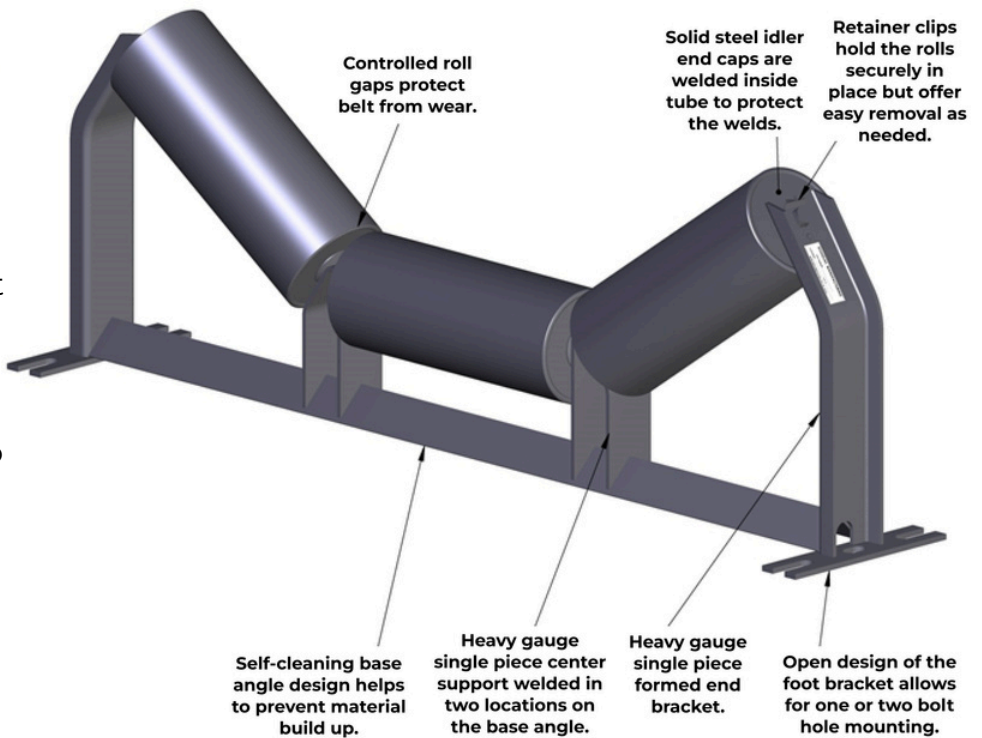

### IDLER SPECIFICATIONS

CLASS	BEARING DIA.	SHAFT DIA.	ROLL DIA.	ROLL THICKNESS	BELT WIDTH
CEMA-B	20mm	7/8"	4" & 5"	.125"	18"-48"
CEMA-C	20mm	7/8"	4", 5", & 6"	.125"	18"-60"
CEMA-D	25mm	1-3/16"	5" & 6"	.149 & .172"	24"-72"
CEMA-E	30mm	1-15/16"	6" & 7"	.187" & .250"	36"-96"

# DRUM PULLEYS

All Douglas/Rulmeca drum pulleys feature our exclusive single piece rolled rim, solid steel pipe or tubing design that ensures long-life, durability and helps ensure proper belt tracking.

One piece solid steel rims and end discs (see diagram below) are welded into a single assembly using the most precise welding methods available to ensure the maximum level of strength and durability. Rubber lagging is applied in our plant using a state of the art autoclave for maximum bond and total quality control.

## Classes available to suit your specific needs:

- Heavy Duty
- Mine Duty
- Premier Duty
- True Engineered Class
- Integral End Discs Available in All Classes
- Bucket Elevator Pulleys
- XT style hubs and bushings are standard
- Keyless Locking Elements Optional
- Stainless steel hubs and bushings in XT Style

## Lagging styles include:

- Standard Lagging in plain, herringbone/chevron, diamond, spiral or with machined finishes
- Ceramic Lagging for increased lagging life and more traction
- Replaceable Rim Lagging®



# WING PULLEYS

The engineered angle of our gussets creates the optimum angle to discharge material away from the pulley and belt and offers enhanced self cleaning ability over other designs.

## Classes available to suit your specific needs:

- Heavy Duty
- Mine Duty
- Bucket Elevator Pulleys

## Round Bar Better by Design

- Full 3/4" Thick Minimum Round

## Contact Bar Can Last 3X Longer

- Helps Prevent Wing Folding
- Round Bar Protects Belt Bottom Cover from Cuts and Tears
- Round Bar Increases Belt Fastener Life
- Self Cleaning Design Discharges Material Helping to Prevent Build Up
- Optional Wing Reinforcing Rings Available
- Spiral Wing Pulleys Available



## Contact Bar Comparison

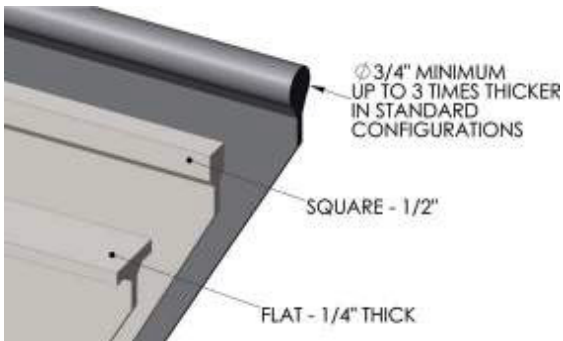

## Douglas Solid 3/4" Steel Round Bar Wing Tips Wear Longer and Retain Roundness.

- Wears twice as long as other manufacturers' flat bar or 1/4" round
- Protects underside of belt from cuts, smoother running
- Large pulleys are fitted with 1" solid steel bars for long life





# VORTEX SPIRAL CLEAN PULLEY

US Patents 10,124,964 B2 and D838428

The Vortex® Spiral Clean Pulley is a new and innovative concept in self-cleaning pulley design. The innovative and patented design is for harsh operating conditions and for those applications where uninterrupted operation is a must.

## Design Features

- More efficient self-cleaning ability than standard wing pulleys.
- Smoother running, reduced vibration, improved sealing at transfer points, and less noise.
- Spiral design aids belt tracking and moves the belt gently toward the middle of the pulley.
- Unique continuous flight design with continuous welds prevents wing folding.
- Plow design moves material to the edge of the pulley and discharges it away from critical areas.
- Abrasion Resistant center and edge support is standard.
- XT style bushings standard. Keyless locking elements optional.



VORTEX® SPIRAL CLEAN PULLEY SECTION CHART						
Available Diameter	12	14	16	18	20	24
Standard Face Widths	26	32	38	44	51	63
Other Sizes Available Upon Request						

# ADDITIONAL PULLEY SYSTEMS

## INTEGRA™ SERIES DRUM & WING PULLEYS

**Integral Bearing Pulleys Offer Many Performance Benefits**

- May be used in all non-drive applications
- Available in drum, self cleaning wing and Vortex™ styles
- Available in Mine Duty & Extreme Duty™ Series
- Integral End disk eliminates chance of hub weld failure
- Piloted flanged bearing design simple to install, maintain & repair
- Sealed for life bearings equal less maintenance
- “Off the Shelf” bearing availability reduces down time and cost
- Up to 33% higher load ratings as a result of reduced bearing centers



## SPIRAL CLEAN PULLEYS

Helically wound flat bar, wrapped over self-cleaning wings, creates continuous belt contact, smooths vibration and reduces the level of noise and amount of vibration, improves sealing at transfer points.

- Less noise.
- Less vibration
- Continuous belt contact.
- XT style bushings standard. Keyless locking elements optional.



## CERAMIC PULLEY LAGGING

Douglas/Rulmeca Ceramic Pulley Lagging delivers substantially increased traction over conventional pulley lagging. Lagging compound features unique enhanced rubber formulation resulting in a tougher, longer lasting product. Durable ceramic tiles last longer than standard rubber lagging resulting in a reduction in the number of times the pulley must be changed over the life of the conveyor system. The ceramic tiles are bonded to the rubber on all four sides as well as the bottom.



- As much as twice the coefficient of friction over non lagged pulleys
- As much as 50% higher coefficient of friction over standard rubber lagging
- Virtually eliminates belt slippage
- Improves belt tracking
- Easily sheds water and dirt
- Lower belt tension and less take-up weight increases life of components and belt

## VULCANIZED PULLEY LAGGING

Douglas/Rulmeca Truck Tire Tuff™ Conveyor Pulley Lagging delivers increased traction and pulley life over non lagged pulleys. Increased traction between the pulley face and the belt bottom cover reduces belt slippage and helps to improve belt tracking. Vulcanized rubber lagging protects the pulley's face from wear and extends pulley service life. Lagging is applied in our plant for total quality control. We also relag and recondition old pulleys making them look and perform like new.



- As much as 50% increase in coefficient of friction over non lagged pulleys
- Protects pulley face from wear and extends pulley service life
- Herringbone and Diamond Grooves shed water and dirt promoting a self-cleaning effect
- Improves Belt Tracking

Standard Thickness	Standard Grooving Patterns	Standard Material	Standard Durometer	Special Durometers	Special Materials
1/4", 3/8", 1/2", 3/4"	Plain Wrap Impression* Herringbone**, Diamond	SBR	60-65 Shore A	40, 80	MSHA, Nitrile, Neoprene, EPDM, SCOF, Tan Neoprene





# REPLACEABLE RIM LAGGING

Replaceable Rim Lagging® is an innovative way to cover new pulleys and recover old pulleys. Engineered sections are made for specific pulleys and electively cover the pulley face in a protective shell of rubber and steel and are an ideal way to save money and time.



## DESIGN FEATURES

- Up to 70% labor savings on installation.
- 30% more coverage resulting in increased traction
- 3/16" solid steel backing plate.
- Vulcanized in house using state of the art computer controlled autoclave.
- 1/2" 60-65 Durometer SBR compound suitable for a wide variety of applications.
- The ability to re-lag the pulley in the field without removing it from the conveyor.
- ROLLED CROWN FACE standard.
- Diamond grooving is standard making installation fast and easy.
- Fewer sections means less gaps and more rubber coverage.
- No excess or wasted material. No undesirable seams.
- Bolt-on option available.
- Ceramic Lagging available.

Quick Comparison Replaceable Rim Lagging vs. Others

PULLEY SIZE	REPLACEABLE RIM LAGGING	OTHERS
20x51	4 Pieces / 4 Rows	8 Pieces / 10 Rows
24x38	4 Pieces / 4 Rows	7 Pieces / 12 Rows
36x44	5 Pieces / 5 Rows	15 Pieces / 18 Rows

Detailed Comparison Replaceable Rim Lagging vs. Others

	REPLACEABLE RIM LAGGING	OTHERS
Number Of Pieces	3	4
Thickness Of Rubber	1/2"	1/2"
Thickness Of Steel	3/16"	1/16" (.0625)
Crown Face Or Flat Face	Option Of Both	Option Of Both
Layout, Measuring And Sawing	None	Yes, Estimated at 3-4 Hours
Number Of Welds	20x1" Tack Welds Estimated To Take 1-2 Hours	84 Tack Welds Estimated To Take As Much As 3 Hours
Total Estimated Time For Installation	1-2 Hours*	6+ Hours*

\* Note that the time reflected is for installing RRL and Slide Lagging in a new application. Additional time will be needed to clean pulleys that are already lagged i.e. for field installation.

Number Of Sections

REPLACEABLE RIM LAGGING® SECTION CHART										
Diameter	12	14	16	18	20	24	30	36	42	48
Weight PIW	2.09	2.44	2.8	3.48	3.63	4.18	5.23	6.28	7.33	8.37
# Of Segments Required	3	3	4	4	4	4	4	5	5	5



CAUTION  
Strong Magnetic  
Field

# MAGNETIC SEPARATORS & PULLEYS

Douglas/Rulmecca magnetic separators are for use in helping separate tramp ferrous metals from conveyed material and are suspended above the belt. Magnetic pulleys are manufactured to CEMA standards and can be used in most any head pulley application.

## CEMA CLASS PERMANENT MAGNETIC HEAD PULLEYS (PMG)

- Meets or exceeds CEMA/ANSI specifications
- Exclusive One Piece Rolled in Crown ensures consistent, proper belt tracking and tighter tolerances
- Remove potentially harmful tramp ferrous metal before it damages expensive processing equipment
- Crown face pulleys are furnished standard, flat face must be specified
- Douglas/Rulmecca hubs and bushings are interchangeable with XT® style
- Stainless Steel Rim standard on all permanent magnetic pulleys



PMG



CBO

## SELF CLEANING PERMANENT MAGNETIC SEPARATOR (CBO - STANDARD POWER OR CBX - SUPER POWER)

- Automatically discharges tramp metal away from the conveyor
- Heavy grade structural steel frame complete with CEMA class lagged crown face head pulley, tail pulley and Slide Tube® belt take-ups
- Heavy duty rubber cover belt standard with hot vulcanized cleats
- Shipped complete, factory test run and ready for installation
- CLASS II shaft mount gear drive with TEFC motor



HMG

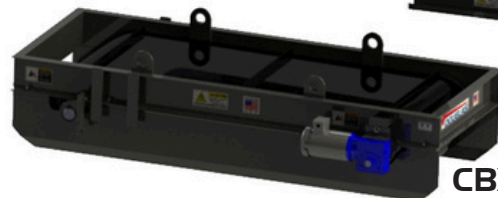

CBX

## STANDARD MANUAL CLEANING PERMANENT MAGNETIC SEPARATORS (HMG - STANDARD POWER OR XMG - SUPER POWER)

- Manual cleaning of ferrous metal required
- Pivot arm or cleaning drawer available for easy cleaning
- Shipped complete and ready for installation



XMG



# ELECTROMAGNETIC SEPARATORS

Douglas/Rulmeca Vanguard™ electromagnetic separators are used in applications where a stronger magnetic field is required due to suspension height, belt speed or burden depth. These magnets are popular for protection of downstream equipment in conveyor systems, including crushers and bark hogs. Electromagnetic separators are oil-filled and utilize state-of-the-art anodized aluminum coils, expansion tanks, and solid core construction for maximum performance and longevity. Douglas/Rulmeca also offers robust power supplies. NEMA 4 enclosures are standard with 480 VDC power supplies. Custom cabinets and special voltage inputs are available on request. Anodized aluminum coils have a standard 10 year warranty.

## **SIZES AVAILABLE**

- 18" to 72" belt widths
- Up to 26" suspension heights
- Custom sizes and application specific designs

## **SELF CLEANING ELECTROMAGNETIC SEPARATORS (ESH)**

- Automatically discharges tramp metal away from the conveyor
- Heavy grade structural steel frame complete with CEMA class lagged
- crown face head pulley, tail pulley and Slide Tube® belt take-ups
- Heavy duty rubber cover belt standard with hot vulcanized cleats
- Shipped complete, factory test run and ready for installation
- CLASS II shaft mount gear drive with TEFC motor (custom drives available)

## **MANUAL CLEANING ELECTROMAGNETIC SEPARATORS (EMH)**

- Manual cleaning of ferrous metal required
- Power off for easy cleaning
- Shipped complete and ready for installation





# METAL DETECTORS

Douglas/Rulmeca Assurance™ metal detectors are available in dual probe configurations. The compact design allows installation in almost any application. The sensitivity can continuously be adjusted if only larger pieces of metal are to be detected. The control unit has self-adjusting electronics housed in a durable, metal cabinet. Power switches and output relays are gold plated providing reliable service. The unit can be integrated into an existing plant control system without any extra components. Ideally suited for Quarries, Mining, Recycling, Slag Processing, Cement, Brick Plants, Forest Products and Recycling as well as other applications.

- Detects both ferrous and non-ferrous metals
- Magnetite from iron oxide and ore are ignored
- Can be operated in close proximity to frequency converters
- Can be operated near magnets (minimum distance of 6 feet)
- Probe(s) constructed of high temperature PVC plastic for durability
- Special secondary sensitivity in area of metal splice or repair clip
- Adjustable primary sensitivity during operation
- Accepts both 110 VAC and 220 VAC single phase power



# IMPACT BEDS AND BARS

Douglas/Rulmeca Titan® Impact Beds are engineered to protect the conveyor belt at key transfer point areas. They help to keep material on the belt where it belongs. Impact beds help to absorb shock loads and support the full width of the conveyor belt. They help to eliminate the cost of idler maintenance and failure. No more bent idler shafts and frames, or worn out rollers to replace.

## TITAN® ADJUSTABLE IMPACT BED ASSEMBLY (IBA)

- Adjustable wing height easily changes from flat, 20° or 35° as needed
- Support arms adjustable from flat to 20° and 35°
- Easy installation, fold one side flat and slide under the belt
- 48" and 60" long beds and bars available
- Center impact rolls available (IRB)

## TITAN® SECTIONAL IMPACT BED ASSEMBLY (ISE)

- Reduce down-time with 3 easily removable sections while the conveyor belt is in place
- Fixed angles of 20°, 35° or 45° (specify at time of order)
- Removable sections allow simple bar replacement
- Sections allow for ease of installation in tight or out of the way applications
- 48" and 60" long beds and bars available
- Center impact rolls available (ISR)

## IMPACT BED BARS (IBB) & T-BOLTS (ITB)

- Replacement Impact Bars mount using field proven T-Bolt locking system
- Profiled leading edge helps increase service life of bars
- Anodized aluminum insert helps to prevent corrosion and ensure simple bar replacement
- Easily retrofits to many other manufacturer's impact bed assemblies
- 48" and 60" long bars available

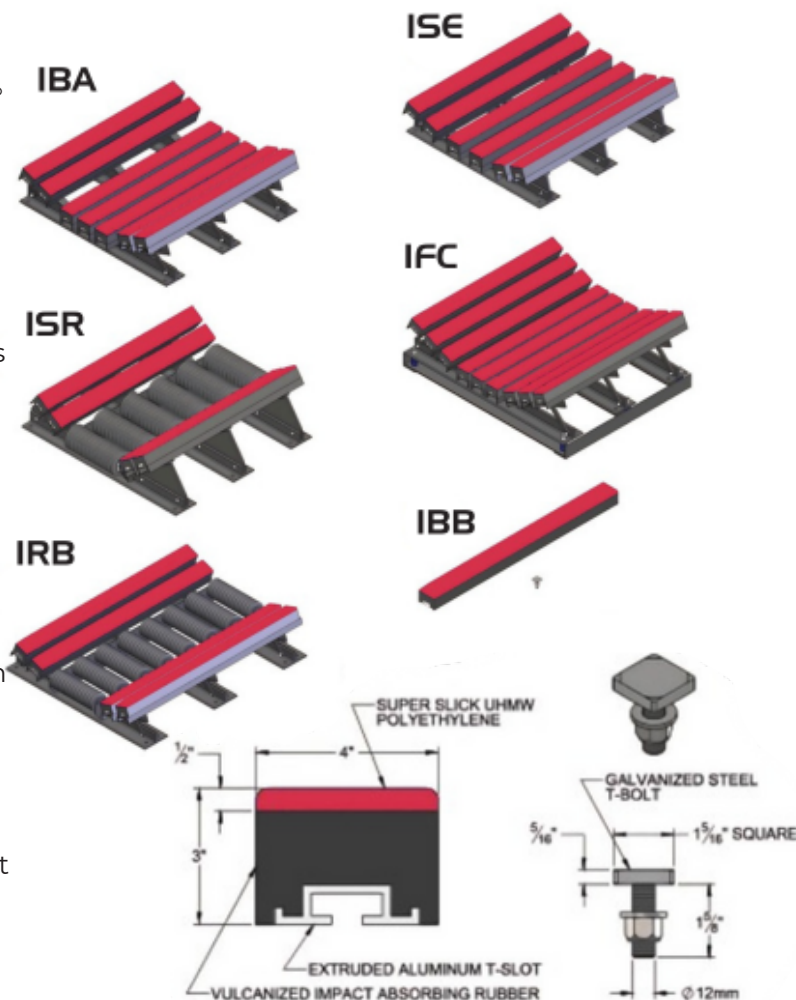



# TAKE-UP FRAMES & ASSEMBLIES

## THE SLIDE TUBE (STT)

Tough and dependable. The space saving design eliminates the need for additional take-up supports and allows for even load distribution.

## THE TOP ANGLE (TAF)

Features a bolted top angle protects the threaded rod and allows for relatively simple bearing removal and replacement. Available with an optional channel or round bar bottom piece to accommodate SKF and Linkbelt or Dodge bearings respectively.

## THE CENTER PULL (CPT)

Suitable to a wide variety of applications. The location of the threaded rod, in the center of the frame and bearing, helps to ensure even tensioning during operation. ACME™ all thread rod standard.

## THE HEAVY DUTY TOP MOUNT (HDT)

Designed for severe applications. The single piece heavy mounting plate is designed for a four bolt pattern style bearing but can be manufactured for two bolt bearings. The extra heavy welded steel construction helps ensure long-life and dependability in the roughest applications.

## THE LIGHT DUTY TOP MOUNT (LDT)

A two piece saddle design that is adjustable and can accommodate a wide range of 2 bolt pillow block ball bearings.

## THE WIDE SLOT SIDE MOUNT (WST)

Designed to fit in very tight spaces. It mounts on the side of a conveyor frame or chute and uses wide slot ball bearings.

All thread rod standard. Bearings are provided separately.

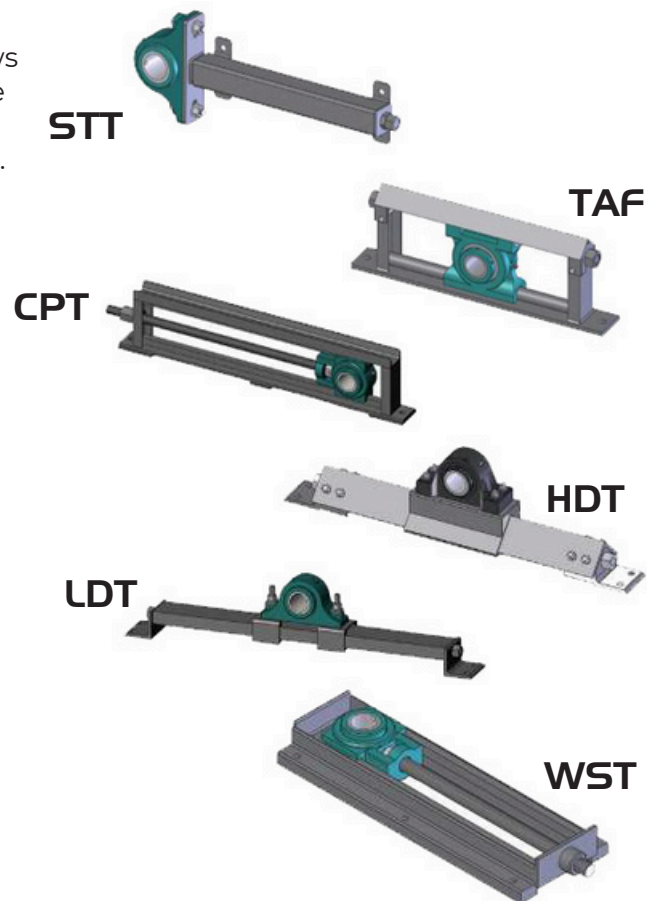



## Building America Starts with Us

At Douglas/Rulmeca, we take pride in engineering and manufacturing high-performance conveyor components that power industries across the nation. With decades of expertise, we deliver reliable solutions that meet the demands of today's toughest applications, all with the fastest lead times in the industry.

## Proudly Made in Alabama

Douglas/Rulmeca conveyor components are proudly manufactured in Alabama. From standard products to custom-engineered solutions, our team is dedicated to Conveying Innovation™ every day.

We maintain inventory at our headquarters in Pell City, Alabama ensuring fast and efficient delivery:

- **Same-Day Shipping:** Stock items are ready to ship immediately.
- **Emergency Support:** Critical orders can be fulfilled in as little as 24 hours.

**At Douglas/Rulmeca, we don't just build components—we build the foundation for progress.**



CEMENT



FOREST PRODUCTS



AGGREGATE

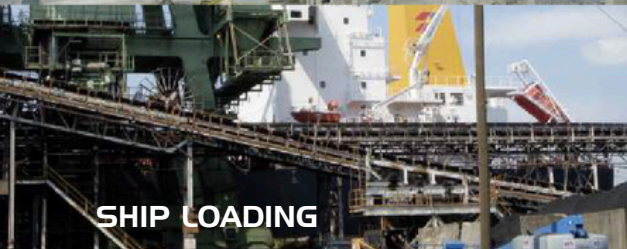

SHIP LOADING



COAL AND POWER GENERATION



MINING



AGRICULTURE

Founded in 1978, Douglas/Rulmeca has established its legacy as an innovator in the conveyor industry. Douglas/Rulmeca's mission is to continue to help our customers make their conveyor systems safer and more profitable. As a member of the Rulmeca Group, Douglas is one of 18 global manufacturing and sales companies, comprised of more than 1,300 team members, and trusted by customers in more than 85 countries.



300 Industrial Park Drive, Pell City, AL 35125 (U.S.A)

Visit us at [douglasmanufacturing.com](http://douglasmanufacturing.com)

Contact us at [sales@douglasmanufacturing.com](mailto:sales@douglasmanufacturing.com)